



Pyramid Trellis

PLEASE READ COMPLETELY BEFORE YOU BEGIN ASSEMBLY

CHECK BOX FOR THESE CONTENTS

- 1 Solid Cedar Cap Piece (1)
- 2 Triangular Trellis Panels (4)

1

HARDWARE

- 1 5/8" Wood screws (28)

2

TOOLS YOU WILL NEED

- Phillips screwdriver (electric driver recommended)

PRELIMINARIES

IF YOU PLAN TO PAINT:

If you wish to paint or stain your trellis...

WORK AREA

A clean, flat work surface (floor, sidewalk, driveway or benchtop) is preferred for Step 1.

PLEASE NOTE: While screw holes are pre-drilled, there are no pilot holes in the wood into which the screws are to be driven. This is because cedar accepts screws very easily and we want to ensure that each screw gets maximum "bite". Be sure to hold both pieces of wood firmly in position when starting each screw. Make sure you are driving them in straight, particularly into the edges of the corner support pieces.

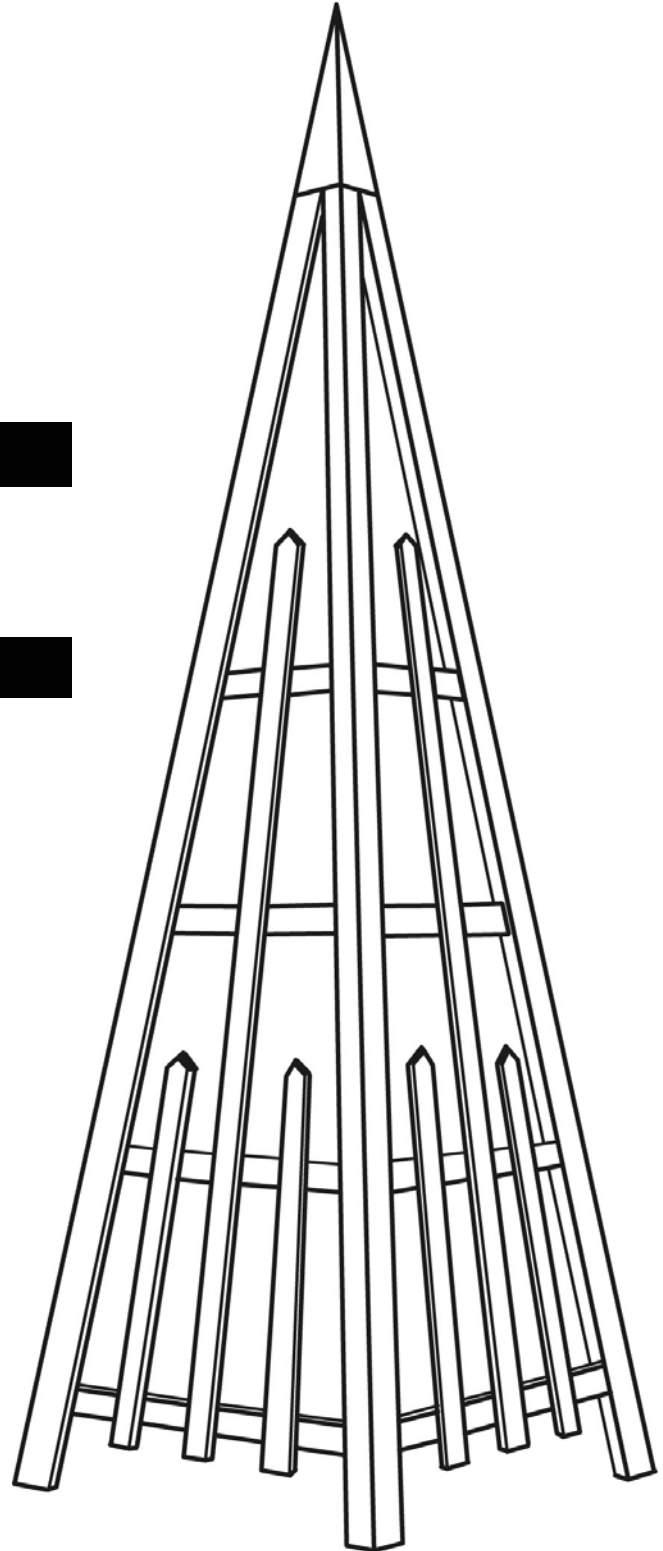

STEP 1: ATTACHING THE FIRST SIDE TO THE PYRAMID CAP

Place the solid cedar pyramid cap on its side on your work surface. Place the “point” of one triangular trellis panel on top of the connector stub at the base of the pyramid, with the cross-members on the underside of the trellis panel (facing down).

Line up the right edge of the right-hand side of the trellis piece so that it is exactly flush with the right side of the connector stub (see Diagram 1). The left edge of the left-hand side of the trellis piece should be flush with the left edge of the pyramid (*not* the connector stub!).

Start screws in the two holes at the top of the trellis piece.

DIAGRAM 1

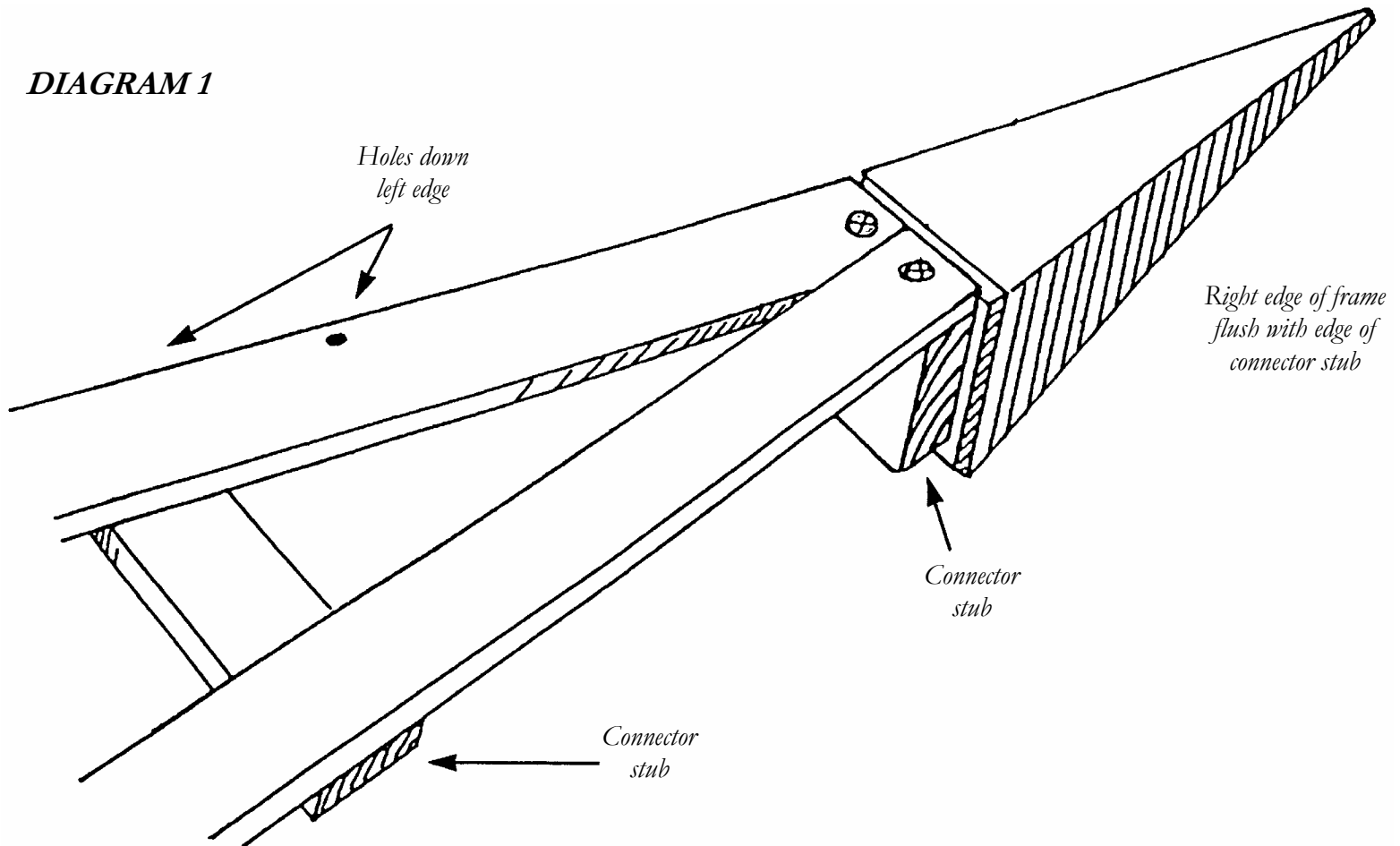

Holding the trellis end firmly against the base of the pyramid cap and with its right edge flush to the connector stub, drive in the right-hand screw. Then drive in the left screw, again keeping a snug fit.

STEP 2: ATTACHING THE SECOND SIDE PANEL

Stand the first frame, with pyramid cap attached, onto its base. Place a second frame, with cross-members inward, on its left. Leaning the two tops together, let the upper end of the second panel rest against the connector stub. You will see that they can now stand unsupported (see Diagram 2).

Moving around to face the second side frame, line up its top right edge against the side of the first frame, with the pyramid cap resting on the top (Diagram 2).

Holding the two sides firmly in this position, drive the right-hand screw into the connector stub. Then drive the second screw, taking care to hold the pyramid snugly against the frame top.

Holding the two trellis pieces firmly together at the corner and squarely aligned, drive a screw through the uppermost hole along the left side of the first piece into the edge of the second panel. This will provide some stiffness as you complete the assembly.

DIAGRAM 2

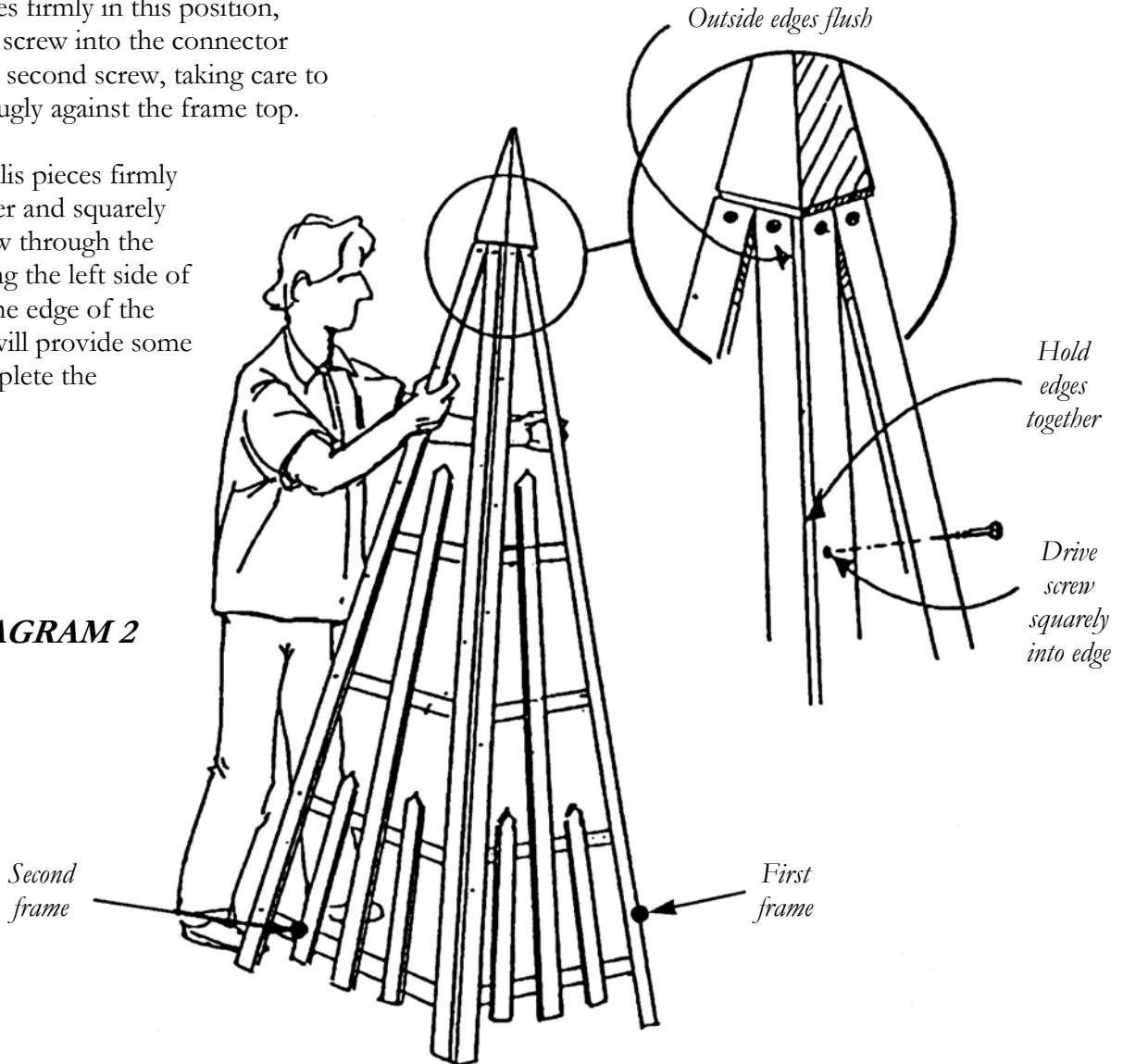

STEP 3: COMPLETING THE ASSEMBLY

Add the remaining two trellis panels in the same manner. You can secure the sides together at the corners as you progress or wait until all sides have been attached to the cap.

NOTE: This pyramid is sufficiently sturdy for its purpose of supporting growing plants, but it is not intended to support concentrated weight on its cross-members. ***IT SHOULD NOT BE CLIMBED ON!***

While pyramids are inherently stable, we recommend anchoring your trellis in place. The easiest way is to tie it to at least two stakes at the corners.