SEALAND®

FINE CHINA TOILET

OWNER'S MANUAL

Traveler® 500 *Plus* Series, 2000 Series,
Traveler Lite® 111 Toilet



**IMPROVED
FLUSH BALL SEAL
for longest-lasting
performance.**

! WARNING

This manual must be read and understood before installation, adjustment, service, or maintenance is performed. Modification of this product can result in property damage.

 **Dometic** 

TABLE OF CONTENTS

Important Information	2	Dimensional Specifications.....	4
Toilet Model Identification	2	Deodorants and Special Tissue	5
How to Use.....	2	Service Tip	5
Installation	3	Troubleshooting Guide	6 - 7
Pedestal and Pedal Cover Installation	3	Ordering Parts	8
Proper Bowl Cleaning	4	Customer Service.....	8
Winterizing	4	Manufacturer's Limited Warranties	8

IMPORTANT INFORMATION

1. Do not use chlorine or caustic chemicals, such as laundry bleach or drain-opening types, in the system. These products damage the seals in toilets and dump valves.
2. Do not permit foreign objects (paper towels, paper cups, diapers, sanitary napkins, etc.) to be flushed through the toilet.
3. Mechanical seal toilets, like SeaLand Traveler units, are designed to only discharge directly into a holding tank. Horizontal pipe runs as found in conventional residential or commercial plumbing systems cannot be accommodated.
4. Toilet must be regularly cleaned and winterized according to "Proper Bowl Cleaning" and "Winterizing" procedures on page 4, or your warranty coverage may be voided.

TOILET MODEL IDENTIFICATION

The model identification label is located on the toilet base and will show the model number and serial number. Follow instructions for removing toilet pedestal cover in "Pedestal and Pedal Cover Installation" on page 3. If label is not available, please refer to "Dimensional Specifications" on page 4 for toilet model identification.

DOMETIC CORPORATION

P.O. BOX 38, 13128 STATE RT 226
BIG PRAIRIE, OH 44611 USA

MODEL NO. **000**
SERIAL NUMBER

000000

HOW TO USE

To prepare the Traveler toilet for use, make sure water supply to the toilet is connected. Turn on water supply and check system for leaks. Flush toilet and check again for leaks.

Make sure the flushing instruction label (shown at right) is in plain sight and easy for guests to read. **If this label is not included in this manual, please contact the SeaLand Product Customer Service Department immediately.**

To properly use the Traveler toilet, follow these simple instructions:

1. **To add water to the toilet**, lift or raise the flush lever until desired water level is reached. Generally, more water is required only when flushing solids.
2. **To flush toilet**, push lever all the way down until contents leave toilet bowl. Water flow pressures vary at different locations, therefore holding the flush lever down for 4-8 seconds may be required. We require a minimum flow at the inlet of the toilet of 2 gpm (7.6 lpm) for proper flushing.
3. Allow flush lever to snap back, which permits positive sealing around the flush ball.
4. A small amount of water should remain in bowl.



Note: Holding flush lever down longer than necessary results in excessive water usage.

INSTALLATION

- To replace an older toilet, turn off water supply to toilet. Disconnect water line at toilet water valve. Unscrew floor bolt nuts and remove toilet. Discard old floor seal and mounting bolts. The old floor flange may be used if it is in good condition and has fastener holes that are positioned correctly. Make sure center of floor flange is at least 11 inches (279 mm) from back wall (Figure A).

NOTE: If old floor flange cannot be used and cannot be removed, please use a SeaLand Universal Mounting Kit, available from your SeaLand dealer.

- When installing new floor flange, make certain that the toilet mounting bolts align properly with Traveler toilet mounting pattern.
- Secure flange to floor using flat head screws through countersunk holes in flange. Insert floor bolts into slotted holes in flange (Figure B).
- If toilet is being installed in a shower stall, apply a 1/4" thick by 3/4" wide bead of glazing compound around the circumference of the floor flange (Figure C).
- Traveler toilet models 111, 510 and 511 will accept handicap or household decorative seats. Remove existing seat and replace with new seat if desired.
- Position floor seal by pressing the floor bolts up through holes in the seal.
- Set toilet in place with bolts protruding up through mounting holes in base (Figure D).
- Install washers and hex nuts provided with toilet. Tighten nuts down equally with standard 7/16" open end wrench. Remove excess glazing compound from around base in shower stall installation.
- Connect water supply line to water valve (1/2" MPT) inlet using appropriate fittings or an extension (Figure E).
- Turn on water supply and flush toilet to test for leaks.
- Attach pedestal and pedal covers to toilet base (see instructions below).

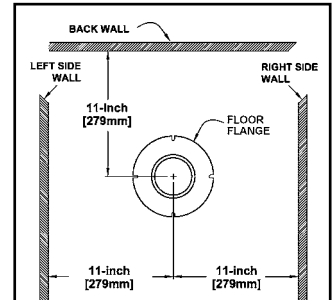

Fig. A

Fig. B

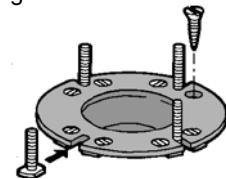

Fig. C

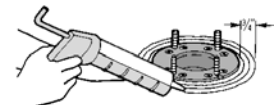

Fig. D

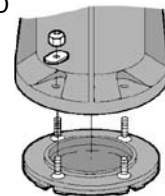
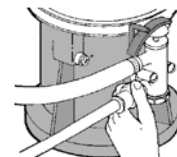
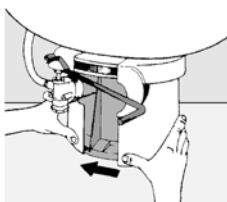

Fig. E



PEDESTAL AND PEDAL COVER INSTALLATION



- Wrap pedestal cover around base so that it closes as shown.

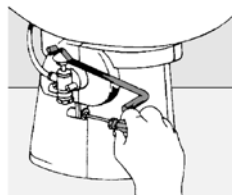

- Tall model – screw cover together. Short model – snap together.

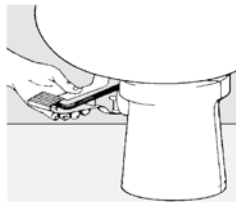

- Slide pedal cover onto foot pedal rod.

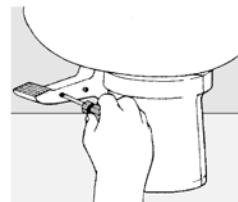

- Secure side plate onto pedal cover with screws.

PROPER BOWL CLEANING

For stubborn stains, use SeaLand® Toilet Bowl Cleaner (Fig. A). It's manufactured especially for use with SeaLand toilets. In certain locations where water is hard, a build-up of lime may dull the toilet bowl finish. Restore the shine with this SeaLand cleaner. If you cannot find it in your area, contact Dometic for your nearest dealer. If the cleaner is not available, you can also use most non-abrasive bathroom and toilet bowl cleaners (Bar Keeper's Friend® spray cleaner, Clorox® toilet bowl cleaner, SaniFlush® toilet bowl cleaner, etc.). Please follow label instructions.



To avoid damaging the Teflon®-coated seal, DO NOT USE:

- abrasives (Comet®, Soft Scrub® cleansers etc.)
- caustic chemicals (Drano® clog remover, etc.)
- lubricants and cleaners containing alcohols or petroleum distillates (Pam® cooking spray, Pine-Sol® cleaner, WD-40® lubricant, etc.).

® Bar Keepers Friend is a registered trademark of SerVaas Laboratories Inc.

® Clorox, Pine-Sol and Soft Scrub are registered trademarks of The Clorox Co.

® Comet is a registered trademark of Prestige Brands International.

® Drano is a registered trademark of S.C. Johnson & Son Inc.

® Pam is a registered trademark of ConAgra Foods.

® Sani-Flush is a registered trademark of Reckitt Benckiser Inc.

® Teflon is a registered trademark of DuPont Co.

® WD-40 is a registered trademark of WD-40 Company.

WINTERIZING

At the end of each season, the Traveler or Traveler Lite toilet should be winterized for storage, by either draining or using potable water-safe antifreeze in the system.

To drain:

1. Thoroughly flush system with fresh water.
2. Empty holding tank.
3. Shut off water supply to toilet(s), and remove inlet waterline (Fig. B).

Do not remove brass cap on bottom of valve.

4. Press flush lever until all water is drained from toilet(s).

To use antifreeze:

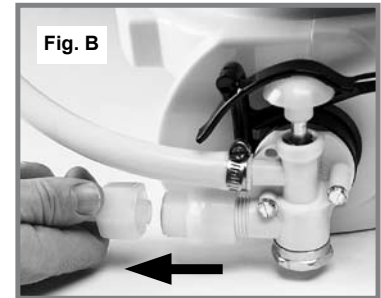

DIMENSIONAL SPECIFICATIONS

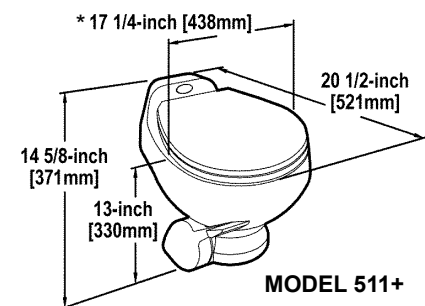

MODEL 511+

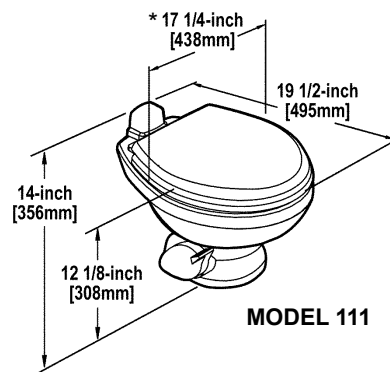

MODEL 111

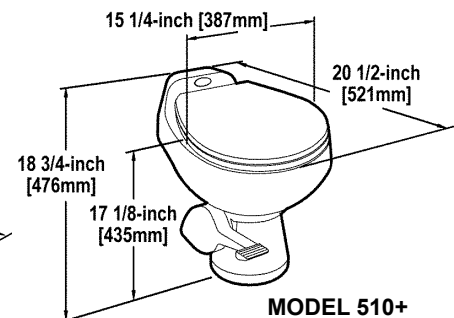

MODEL 510+

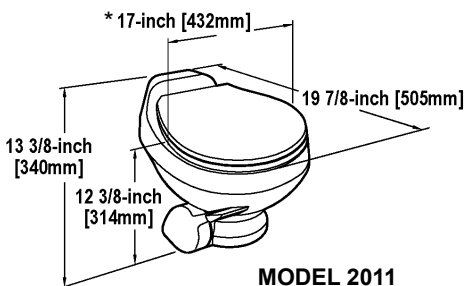

MODEL 2011

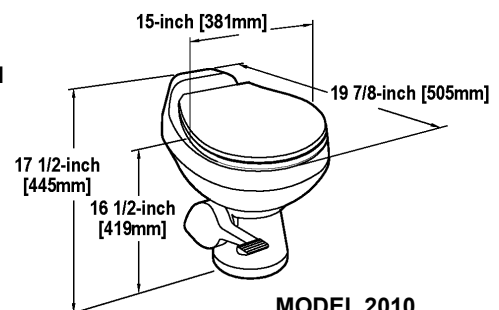

MODEL 2010

All dimensions may vary
± 3/8-inch (10mm).

* Width measurement includes flush pedal.

DEODORANTS AND SPECIAL TISSUE

Traveler toilets require the regular addition of a deodorant product to reduce holding tank malodors and to help break down holding tank contents. Several factors should be considered in selecting a deodorant product.

Liquid or Granulated: Liquid products obviously work more quickly by readily going into solution. Granulated powder formulations, on the other hand, have the advantage of requiring less storage space and are less likely to leak if the package is inadvertently damaged.

Formaldehyde versus Non-Formaldehyde: Dometic manufactures both types of deodorants. Generally speaking, formaldehyde formulas control odor very effectively at all temperatures and with all degrees of water hardness. SeaLand® Environment-Friendly brand, which is formaldehyde free, is similarly effective.

How Much Deodorant and How to Add It: The deodorant is added directly into the toilet bowl, then flushed into the holding tank. Follow bottle or package instructions. Conditions of extremely warm weather, longer waste holding time and larger tank capacities may require more deodorant treatment. Also, to maintain optimum efficiency in odor control, the waste holding tank should be cleaned thoroughly at least once or more each season depending on use.

Why Not Use Household Toilet Paper in Your Traveler Toilet. Household tissues often contain adhesives which bond together the paper fibers from which the tissue is made. The adhesives prevent the tissue from breaking apart, and their use in “ultra-low flow” systems can cause system clogging. SeaLand tissue is especially designed for use in low water toilet systems. Its rapid dissolving properties minimize the amount of residual paper in the holding tank and allow deodorizers to work more efficiently.

SeaLand Brand versus Other Brands: We constantly strive to provide our system owners with effective products that have minimal environmental impact and good value. Many deodorant products do not measure up to our standards of performance and value.

 <p>SeaLand® Granulated Deodorant Six 2-oz. pouches</p> <p>Part No. 379626002</p>	 <p>SeaLand® Liquid Deodorant Two 8-oz. bottles</p> <p>Part No. 379224008</p>	 <p>SeaLand® Toilet Bowl Cleaner 16-oz. bottle</p> <p>Part No. 379314016</p>	 <p>SeaLand® Liquid Deodorant - Environment Friendly 32-oz. bottle</p> <p>Part No. 379114032</p>	 <p>SeaLand® Rapid-Dissolving Toilet Tissue Four 400-sheet rolls</p> <p>Part No. 379441204</p>
---	---	--	---	--

SERVICE TIP

Checking for water leaks behind or under toilets or other appliances can make it difficult to locate the source. Dripping water at room temperature makes it difficult to feel wetness. Taking four or five sheets of toilet tissue and wiping all seams and waterline connections offers a simple means of locating the general area of the leakage. Start at the top of the unit since gravity will cause a leak to run downward. When the tissue comes in contact with the leaking water, it will immediately change texture.

TROUBLESHOOTING GUIDE

TRAVELER TOILET BASE ASSEMBLY (except model 110)

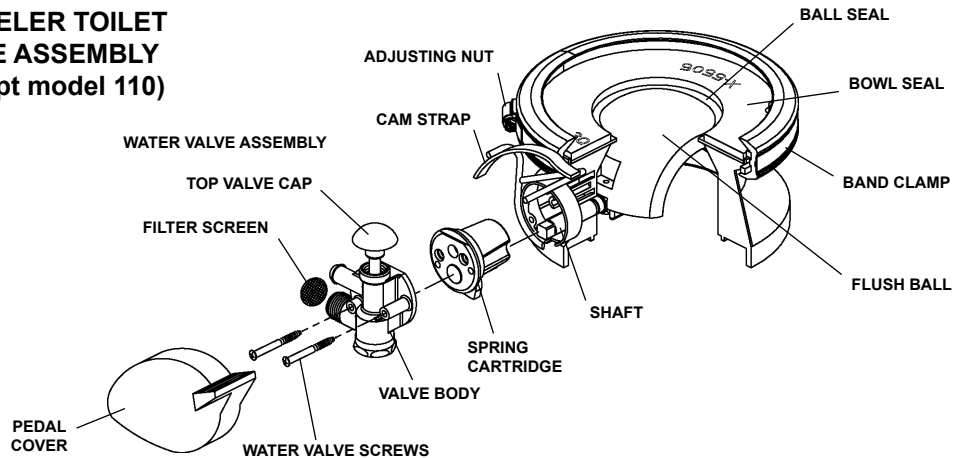

TRAVELER TOILET BOWL, REAR VIEW (Models 510+, 511+, 2010, 2011)

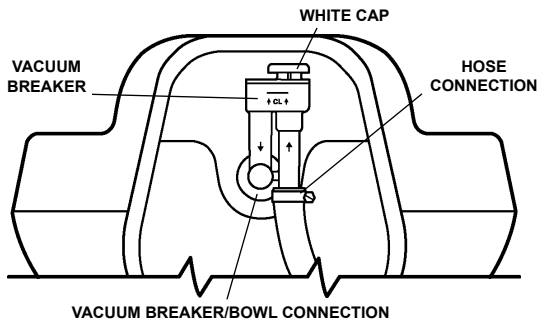

TRAVELER LITE TOILET BOWL, REAR VIEW (Model 111)

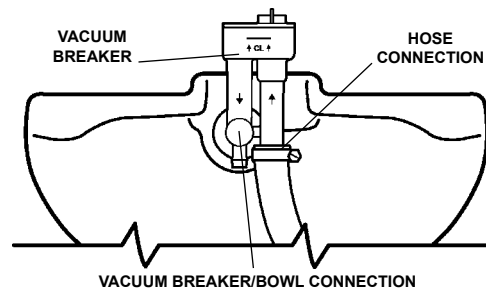

Problem	Possible Cause	Service Instructions
1. Toilet emits odor (flush ball open).	<ul style="list-style-type: none"> a. Odor emitting from base of toilet. b. Plugged holding tank vent line. 	<ul style="list-style-type: none"> a. Use SeaLand brand deodorants. b. Clear obstruction from vent line.
2. Water will not stay in bowl.	<ul style="list-style-type: none"> a. Loose band clamp. b. Improper seal around flush ball due to dirt or debris on flush ball. c. Worn or damaged seal. d. Worn or damaged flush ball. 	<ul style="list-style-type: none"> a. Tighten adjusting screw. b. Inspect flush ball for foreign debris. Clean flush ball if needed (cleaning tool available – part no. 385310805). c. Replace seal. d. Replace flush ball.
3. Flush ball will not close completely.	<ul style="list-style-type: none"> a. Too much friction between flush ball and seal. b. Water valve screws are too tight. c. Defective spring cartridge. 	<ul style="list-style-type: none"> a. Lubricate between flush ball and seal with furniture polish (e.g. Pledge® furniture polish). b. Loosen screws slightly. c. Check spring tension by pushing flush lever down, then release it suddenly. If lever does not snap back to original position, replace spring cartridge.

© Pledge is a registered trademark of S.C. Johnson & Son Inc.

TROUBLESHOOTING GUIDE (cont'd)

Problem	Possible Cause	Service Instructions
4. Flush ball will not open.	<ul style="list-style-type: none"> a. Broken shaft. b. Shaft not fully engaged in the spring cartridge. 	<ul style="list-style-type: none"> a. Replace shaft. b. Put pressure on shaft from under the flush ball (pushing into spring cartridge) until it engages. You may have to rotate flush ball slightly until shaft lines up with square in spring cartridge.
5. Flush ball does not open completely. Applies to short-base units mounted on step or riser only.	<ul style="list-style-type: none"> a. Floor flange interferes with flush ball rotation. 	<ul style="list-style-type: none"> a. Loosen mounting bolts and push toilet base back. If this does not solve problem, install a SeaLand Universal Mounting Kit (part no. 310139, 310140, or 310141) with existing floor flange.
6. Water does not shut off in toilet (toilet overflows).	<ul style="list-style-type: none"> a. Not enough clearance between cam strap and top of water valve cap. b. Dirt lodged in water valve seal. c. Worn or defective water valve. d. Worn or defective spring cartridge. 	<ul style="list-style-type: none"> a. Adjust cam strap to have .02" - .06" (.5mm - 1.5mm) clearance with top of water valve cap. b. Dissassemble and clean water valve. c. Replace water valve. d. Replace spring cartridge.
7. Hand spray unit leaks.	<ul style="list-style-type: none"> a. Hand sprayer is defective. 	<ul style="list-style-type: none"> a. Replace hand sprayer.
8. Water does not enter toilet bowl properly.	<ul style="list-style-type: none"> a. Insufficient water flow rate at toilet. b. Water valve clogged. c. Plugged rim wash holes in toilet. 	<ul style="list-style-type: none"> a. Check water flow rate at toilet. Rate should be 2 gpm (7.6 lpm) at toilet. b. Remove and clean screen located at inlet of water valve. c. Clean holes. If still a problem, replace the toilet bowl.
9. Water is leaking from water valve.	<ul style="list-style-type: none"> a. Water valve body cracked due to freeze damage. b. Water line connection is loose or not seated properly. c. Defective water valve. d. Stripped threads. 	<ul style="list-style-type: none"> a. Replace water valve. b. Insure that threads are not cross-threaded and tighten. c. Replace water valve. d. Replace water valve.
10. Water is leaking from bottom of toilet base.	<ul style="list-style-type: none"> a. Toilet is not secured to floor. b. Worn or defective toilet mounting floor seal. c. Cracked base. d. Worn or defective floor flange. 	<ul style="list-style-type: none"> a. Tighten toilet mounting bolts. b. Replace floor seal between floor flange and toilet base. c. Replace base assembly. d. Replace floor flange.
11. Water is leaking from rear of toilet bowl.	<ul style="list-style-type: none"> a. Worn or defective vacuum breaker. b. Loose vacuum breaker. c. Cracked or defective toilet bowl. 	<ul style="list-style-type: none"> a. Remove white cap from vacuum breaker. Flush toilet. If water leaks during flush, vacuum breaker needs to be replaced. b. Secure vacuum breaker connection. If loose, push breaker into bowl. c. Replace toilet bowl.
12. Water is leaking from the base/toilet connection.	<ul style="list-style-type: none"> a. Band clamp may be loose. b. Ball/bowl seal may be worn or defective. 	<ul style="list-style-type: none"> a. Remove plastic base cover and tighten the band clamp. b. Replace ball/bowl seal.

ORDERING PARTS

Dometic is ready to assist you in the event service is required. Before calling, please have the following information available. Your cooperation in having this information ready is appreciated and allows us to better meet your needs.

1. Toilet Model Number
2. Serial Number
3. Part Number, Description and Quantity (see separate Parts List)

CUSTOMER SERVICE

There is a strong, worldwide network to assist in servicing and maintaining your sanitation system. For the Authorized Service Center near you, please call from 8:00 a.m. to 5:00 p.m. (ET) Monday through Friday.

MANUFACTURER'S THREE-YEAR AND TEN-YEAR LIMITED WARRANTIES

Dometic Corporation warrants, to the original purchaser only, that this Traveler® gravity discharge toilet, if used for personal, family or household-like purposes, is free from defects in material and workmanship for a period of three (3) years from the date of purchase.

Dometic also warrants, to the original purchaser only, that the ceramic portion of the toilet bowl will not discolor, stain, scratch or craze for a period of ten (10) years if used for personal, family or household-like purposes, and is regularly cleaned as described in the product's owner's manual.

If this Dometic product is placed in commercial or business use, it will be warranted, to the original purchaser only, to be free of defects in material and workmanship for a period of ninety (90) days from the date of purchase.

Dometic reserves the right to replace or repair any part of this product that proves, upon inspection by Dometic, to be defective in material or workmanship. All labor and transportation costs or charges incidental to warranty service are to be borne by the purchaser-user.

EXCLUSIONS

IN NO EVENT SHALL **DOMETIC** BE LIABLE FOR INCIDENTAL OR CONSEQUENTIAL DAMAGES, FOR DAMAGES RESULTING FROM IMPROPER INSTALLATION, OR FOR DAMAGES CAUSED BY NEGLIGENCE, ABUSE, ALTERATION, OR USE OF UNAUTHORIZED COMPONENTS. THIS INCLUDES FAILURES WHICH MAY RESULT FROM NOT FOLLOWING THE WINTERIZATION OR CLEANING PROCEDURE AS DESCRIBED IN THIS OWNER'S MANUAL. ALL IMPLIED WARRANTIES, INCLUDING ANY IMPLIED WARRANTY OF MERCHANTABILITY OR FITNESS FOR ANY PARTICULAR PURPOSE, ARE LIMITED TO A PERIOD OF ONE (1) YEAR FROM DATE OF PURCHASE.

IMPLIED WARRANTIES

No person is authorized to change, add to, or create any warranty or obligation other than that set forth herein.

Implied warranties, including those of merchantability and fitness for a particular purpose, are limited to one (1) year from the date of purchase for products used for personal, family or household-like purposes, and ninety (90) days from the date of purchase for products placed in commercial or business use.

OTHER RIGHTS

Some states do not allow limitations on the duration of an implied warranty, and some states do not allow exclusions or limitations regarding incidental or consequential damages; so, the above limitations may not apply to you. This warranty gives you specific legal rights, and you may have other rights which vary from state to state.

To obtain warranty service, first contact your local dealer from whom you purchased this product.

Dometic is a customer driven, world-leading provider of innovative leisure products for the caravan, motorhome and marine markets. Dometic offers a complete range of air conditioners, refrigerators, awnings, cookers, sanitation systems, lighting, windows, doors and other equipment that makes leisure life more comfortable away from home.

Dometic also provides refrigerators for specific use in hotel rooms, offices and for storage of medical products and wine. Dometic's products are sold in almost 100 countries and are produced mainly in Dometic's own production facilities around the world. Dometic has more than 4,400 employees.



® Registered; ™ Trademark of Dometic Corporation
© Dometic Corporation